

PCT

WORLD INTELLECTUAL PROPERTY ORGANIZATION
International Bureau

INTERNATIONAL APPLICATION PUBLISHED UNDER THE PATENT COOPERATION TREATY (PCT)

<p>(51) International Patent Classification ⁶ : E04F 15/02, 15/14, 13/08</p>	<p>A1</p>	<p>(11) International Publication Number: WO 96/2771 (43) International Publication Date: 12 September 1996 (12.09.96)</p>
<p>(21) International Application Number: PCT/SE96/00291 (22) International Filing Date: 7 March 1996 (07.03.96) (30) Priority Data: 9500809-0 7 March 1995 (07.03.95) SE (71) Applicant (for all designated States except US): PERSTORP FLOORING AB [SE/SE]; Strandridaregatan 8, S-231 25 Trelleborg (SE). (72) Inventor; and (75) Inventor/Applicant (for US only): MÅRTENSSON, Göran [SE/SE]; Vallby 878, S-231 97 Klagstorp (SE). (74) Agent: STENBERG, Yngve; Perstorp AB, S-284 80 Perstorp (SE).</p>	<p>(81) Designated States: AM, AT, AU, BB, BG, BR, BY, CA, C, CN, CZ, DE, DK, EE, ES, FI, GB, GE, HU, IS, JP, K, KG, KP, KR, KZ, LK, LR, LT, LU, LV, MD, MG, M, MW, MX, NO, NZ, PL, PT, RO, RU, SD, SE, SG, SI, SJ, TJ, TM, TT, UA, UG, US, UZ, VN, ARIPO patent (K, LS, MW, SD, SZ, UG), European patent (AT, BE, CH, DK, ES, FI, FR, GB, GR, IE, IT, LU, MC, NL, PT, SE OAPI patent (BF, BJ, CF, CG, CI, CM, GA, GN, ML, MN, NE, SN, TD, TG).</p> <p>Published With international search report. Before the expiration of the time limit for amending the claims and to be republished in the event of the receipt of amendments.</p>	

(54) Title: FLOORING PANEL OR WALL PANEL

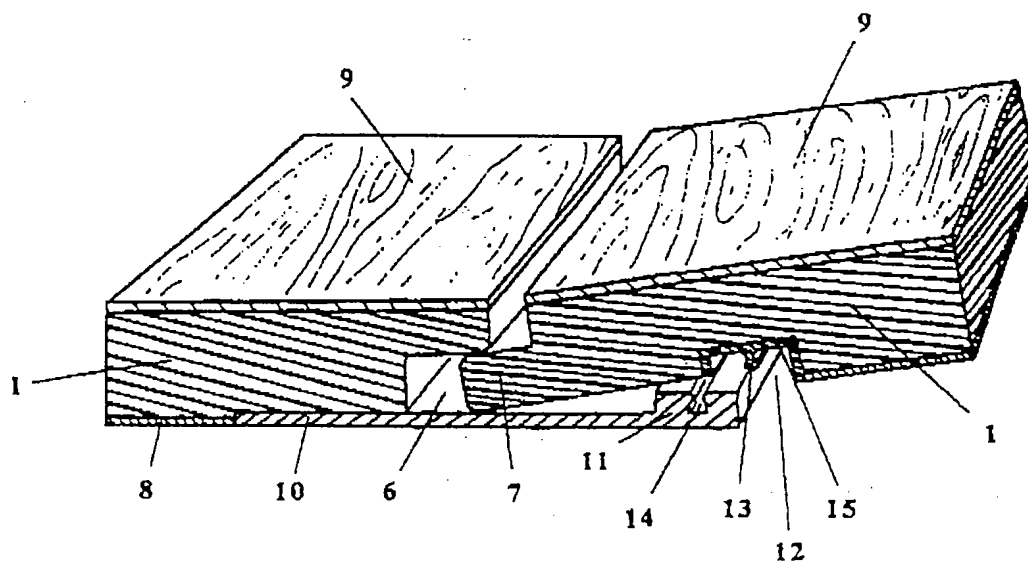

(57) Abstract

Flooring panel or wall panel provided with a locking means in the form of a groove (6) and a tongue (7) fitting in the groove (6) whereby a tongue/groove joint for assembling of the panels is formed. The under side of the groove (6) consists of a ledge (10) fixed to the under side (8) of the panel and protruding in respect of the upper side (9) of the panel. The ledge (10) is in its outer part provided with an upwards directed edge (11). The panel (1) is along the adjacent sides (2, 4) provided with a tongue (7), parallel to these sides (2, 4) on the under side furnished with a groove (12) having such a size and such a distance from these sides that the groove (12) with a rather close fitting can receive the upwards directed edge (11) of the ledge (10) on a connecting panel (1). The ledge (10) and the groove (12) are furnished with complementary locking means for locking the edge (11) in the groove (12), whereby the panels are fixed to each other and prevented from unintentional separation.

FOR THE PURPOSES OF INFORMATION ONLY

Codes used to identify States party to the PCT on the front pages of pamphlets publishing international applications under the PCT.

AM	Armenia	GB	United Kingdom	MW	Malawi
AT	Austria	GE	Georgia	MX	Mexico
AU	Australia	GN	Guinea	NE	Niger
BB	Barbados	GR	Greece	NL	Netherlands
BE	Belgium	HU	Hungary	NO	Norway
BF	Burkina Faso	IE	Ireland	NZ	New Zealand
BG	Bulgaria	IT	Italy	PL	Poland
BJ	Benin	JP	Japan	PT	Portugal
BR	Brazil	KE	Kenya	RO	Romania
BY	Belarus	KG	Kyrgyzstan	RU	Russian Federation
CA	Canada	KP	Democratic People's Republic of Korea	SD	Sudan
CF	Central African Republic	KR	Republic of Korea	SE	Sweden
CG	Congo	KZ	Kazakhstan	SG	Singapore
CH	Switzerland	LI	Liechtenstein	SI	Slovenia
CI	Côte d'Ivoire	LK	Sri Lanka	SK	Slovakia
CM	Cameroon	LR	Liberia	SN	Senegal
CN	China	LT	Lithuania	SZ	Swaziland
CS	Czechoslovakia	LU	Luxembourg	TD	Chad
CZ	Czech Republic	LV	Latvia	TG	Togo
DE	Germany	MC	Monaco	TJ	Tajikistan
DK	Denmark	MD	Republic of Moldova	TT	Trinidad and Tobago
EE	Estonia	MG	Madagascar	UA	Ukraine
ES	Spain	ML	Mali	UG	Uganda
FI	Finland	MN	Mongolia	US	United States of America
FR	France	MR	Mauritania	UZ	Uzbekistan
GA	Gabon			VN	Viet Nam

WO 96/27719

FCT/SE96/00291

1

FLOORING PANEL OR WALL PANEL

The present invention relates to a flooring panel or wall panel, preferably of thermosetting laminate having two pairs of opposite parallel side edges, two of these side edges being provided with a locking means in the form of a groove and the other two with a tongue fitting in the groove, whereby a tongue/groove joint for assembling of the panels is formed.

During the last few years laminated floors have achieved and increased popularity and on many markets they are beginning to replace parquet floors and wall-to-wall carpets. At the production of laminated floors a decorative thermosetting laminate is first produced. This laminate usually consists of a base layer of paper sheets impregnated with phenol-formaldehyde resin and a decorative surface layer consisting of a decor paper sheet impregnated with melamine-formaldehyde resin. The laminate is produced by pressing the different layers at a high pressure and an increased temperature.

The laminate obtained is then glued to a carrier of particle board for instance or used as such without any carrier and it is then called compact laminate. The laminated panel thus produced is then sawn up to a number of floor boards which are provided with groove and tongue at the long sides and the short sides. Often the floor boards produced have a thickness of about 7 mm, a length of 120 cm and a width of about 20 cm. Thereby they can usually be put on top of an existing flooring material at a renovation. According to another alternative, instead one or more of the above decorative sheets can be laminated directly towards a base sheet of particle board for instance.

At the assemblage of such a flooring, glue is normally applied in the groove when the floor boards are assembled. Therefore, it will be difficult to change a damaged board or to remove a whole flooring and for instance install it in another room.

To avoid the above problem efforts have been made to achieve floor boards which can be assembled without glue and in spite of that give stable floorings where the floor boards are safely fixed to each other in the joints.

This is a difficult problem especially since you have to consider that the underlayer for the floor boards is not always straight and plain.

In addition you must have in mind that a flooring construction which solves the above problems should not be too technically complicated and/or too expensive.

CONFIRMATION

WO 96/27719

PCT/SE96/00291

2

Constructions with double sided adhesive tape are not acceptable either since the adhesion will stop when the glue is aged.

According to the present invention it has been possible to solve the above problem and bring about a flooring panel or wall panel, preferably of thermosetting laminate having two pairs of opposite parallel side edges, two of these adjacent side edges being provided with a locking means in the form of a groove and the other two with a tongue fitting in the groove, whereby a tongue/groove joint for assembling of the panels is formed.

The panel is characterized in that the under side of the groove consists of a ledge fixed to the under side of the panel and protruding in respect of the upper side of the panel. The ledge is in its outer part provided with an upwards directed edge.

The panel is along the two adjacent sides provided with a tongue, parallelly to these sides on the under side furnished with a groove having such a size and such a distance from these sides that the groove with a rather close fitting can receive the upwards directed edge of the ledge on a connecting panel. The ledge and the groove are furnished with complementary locking means for locking the edge in the groove, whereby the panels are fixed to each other and prevented from unintentional separation.

According to one preferred embodiment of the invention the complementary locking means consist of a snapping web and a cooperating snapping groove, preferably provided with undercut edges.

Preferably the snapping groove runs parallelly with the long side of the ledge and is formed in the upwards directed edge of the ledge.

Suitably the snapping web is fixed in the bottom of the groove in such a manner that it is directed downwards or makes a downwards directed integrated part of a ledge arranged in the groove.

The snapping groove preferably runs along the whole length of the two adjacent sides of the panel mentioned above and the snapping web has preferably the same length as the snapping groove. The snapping web can be divided in two or more shorter parts possibly in the form of separate snapping heads.

According to another embodiment of the invention the complementary locking means consist of springs, snapping webs or the like arranged at least along one of the vertical edges of the groove. These springs, snapping webs or the like will press against at least one side of the upwards directed edge.

WO 96/27719

PCT/SE96/00291

3

Suitably the upwards directed edge is broadest at the top, furnished with indentations along the side edges or designed in another way which makes it possible for the springs, the snapping webs or the like to lock the upwards directed edge when it is inserted into the groove.

It is suitable that the ledge on the under side of the panel is arranged in a recess whereby the under side of the ledge and the rest of the under side of the panel will be flush with each other. The ledge is then usually glued to the under side of the panel.

Normally at least one of the ledge and the snapping web is made of an elastic material such as plastic, rubber or the like. In this way a good snap-together function can be secured. For instance the other part can be made of aluminium. Alternatively, both parts are made of the above mentioned elastic material.

As mentioned above the panel can consist of a thermosetting laminate glued to a carrier or base of particle board, or solely of a compact thermosetting laminate without any carrier. In addition to these materials the panel can be made of a water resistant or non water absorbing base with a surface layer consisting of paint, a thermoplastic foil, a paper sheet impregnated with thermosetting resin or of a thermosetting laminate. One suitable base of this kind is a board produced by pressing wood particles or wood chips with a thermoplastic, preferably at an increased temperature.

The invention will be explained further in connection with the enclosed figures of which figure 1 schematically from above shows one embodiment of a panel according to the invention. Figure 2 shows the same panel from below. Figure 3 illustrates a cross section through one embodiment of a flooring panel or wall panel where two such panels are to be assembled. Figure 4 shows a cross section through another embodiment of a flooring panel or wall panel where two such panels have been assembled.

The panel 1 has two opposite parallel short sides 2, 3 (figures 1 and 2) and two opposite parallel long sides 4, 5 (figures 1 and 2). However, the panel can be square instead of rectangular. One long side 5 and one short side 3 are provided with a groove 6 (figure 3) and the remaining sides 2, 4 are provided with a tongue 7 (figure 3).

The under side of the groove 6 consists of a ledge 10 fixed to the under side 8 of the panel 1 (figures 3 and 4) by glue or the like. The ledge 10 protrudes from the panel as compared to the upper side 9 of the panel. In its outer part the ledge 10 has an upwards directed edge 11.

WO 96/27719

PCT/SE96/00291

On the under side the panel 1 has a groove 12 along the sides 2 and 4 which have a tongue 7. The groove is arranged parallelly to these sides. The size of the grooves 12 and their distance from the sides 2 and 4 respectively are adapted in such a manner that the grooves 12 can receive the upwards directed edge 11 of the ledge 10 of a connecting panel 1 with a rather close fitting. The ledge 10 and the groove 12 are provided with complementary locking means for locking the ledge 11 in the groove 12. The panels 1 are thereby fixed to each other and prevented from unintentional separation.

At the embodiment shown on figure 3 one part of the complementary locking means consists of a downwards directed snapping web 13 constituting an integrated part of a ledge 15 fixed by glue for instance in the groove 12. Another cooperating part of the complementary locking means is a snapping groove 14 in the upwards directed edge 11.

At the assemblage of the panels 1 to a floor covering the panels are suitably assembled row by row. Then the tongue 7 of one panel 1 is inserted into the groove 6 of a previously installed panel 1. The panel which is inserted is suitably lifted up a bit as shown in figure 3. When the tongue 7 has reached its place in the groove 6 the snapping web 13 is pushed down into the snapping groove 14. The groove/tongue joint and the snapping web 13 in the groove 14 then prevent the flooring panels from releasing from each other vertically. The snap-together joint 13, 14 assists in preventing the flooring panels from separating horizontally. Since the edge 11 will be in engagement with the groove 12 the panels will be prevented from horizontal separation by these parts too.

The snapping groove 14 is suitably formed with undercut edges while the snapping web 13 has a complementary cross section. The groove 14 runs along the whole long side 5 and the short side 3 respectively of the panel 1. The snapping web 13 has the same length as the groove 14.

The ledge 10 is made of aluminium and glued in a recess on the under side of the panel 1. As shown on figure 3 the recess for the ledge 10 has such a dimension that the under side of the ledge 10 will be flush with the rest of the under side of the panel 1.

At a disassembly of the flooring panels you suitably go in the opposite direction as compared to the assembly. Thus, you lift up the finally assembled row, panel by panel so that the snapping webs 13 are released from the groove 14 and the tongue 7 can be pulled out of the groove 6.

WO 96/27719

PCT/SE96/00291

5

At the second embodiment illustrated on figure 4 the complementary locking means consist of longitudinal outer surfaces 18 on the upwards directed edge 11 and springs, snapping webs or the like 16 arranged along at least one of the vertical edges 17 of the groove 12.

The springs, the snapping webs or the like 16 will press against the outer surfaces 18 and lock the edge 11 in the groove 12. To bring about a good locking of the edge 11 it is broadest at the top and inclines inwards. In this way the parts 16 get a good grip against the inclined sides 18.

At this embodiment one end of the ledge 10 has been designed with about the same thickness as the edge 11 in the other end. However, this is not necessary. The ledge 10 can have an even thickness in the same way as at the embodiment shown in figure 3.

The flooring or wall panels according to figure 4 can be assembled and disassembled in the same way as disclosed above in respect of the embodiment shown on figure 3.

According to both embodiments above a solid flooring is obtained where the floor panels can be assembled without glue and in spite of that are firmly fixed to each other in the joints.

The invention is not limited to the embodiments shown since these can be modified in different ways within the scope of the invention.

WO 96/27719

PCT/SE96/00291

6

Claims

1. Flooring panel or wall panel, preferably of thermosetting laminate having two pairs of opposite parallel side edges (2, 3 and 4, 5 respectively), two of these side edges (3 and 5) being provided with a locking means in the form of a groove (6) and the other two (2, 4) with a tongue (7) fitting in the groove (6), whereby a tongue/groove joint for assembling of the panels is formed characterized in that the under side of the groove (6) consists of a ledge (10) fixed to the under side (8) of the panel and protruding in respect of the upper side (9) of the panel, which ledge (10) in its outer part is provided with an upwards directed edge (11), that the panel (1) along the adjacent sides (2, 4) provided with an tongue (7), parallelly to these sides (2, 4) on the under side is furnished with a groove (12) having such a size and such a distance from these sides that the groove (12) with a rather close fitting can receive the upwards directed edge (11) of the ledge (10) on a connecting panel (1), that the ledge (10) and the groove (12) are furnished with complementary locking means for locking the edge (11) in the groove (12), whereby the panels are fixed to each other and prevented from unintentional separation.
2. Panel according to claim 1, characterized in that the complementary locking means consist of a snapping web (13) and a cooperating snapping groove (14) preferably provided with undercut edges.
3. Panel according to claim 1 or 2, characterized in that the groove (14) runs parallelly with the long side of the ledge (10) and that it is formed in the upwards directed edge (11) of the ledge (10).
4. Panel according to any one of claims 1-3, characterized in that the snapping web (13) is fixed in the bottom of the groove (12) in such a manner that it is directed downwards or makes a downwards directed integrated part of a ledge (15) arranged in the groove (12).
5. Panel according to any one of claims 1-4, characterized in that the snapping groove (14) preferably runs along the whole length of the sides (5) and (3) respectively and that the snapping web (13) preferably has the same length as the groove (14).
6. Panel according to any one of claims 1-5, characterized in that the snapping web (13) is divided in two or more shorter parts.

WO 96/27719

7

PCT/SE96/00291

7. Panel according to claim 1 or 2, characterized in that the complementary locking means consist of springs, snapping webs or the like (16) arranged along at least one of the vertical edges (17) of the groove (12), which springs, snapping webs or the like (16) press against at least one side (18) of the upwards directed edge (11).
8. Panel according to claim 7, characterized in that the upwards directed edge (11) is broadest at the top, provided with indentations along the side edges or designed in another way which makes it possible for the springs, the snapping webs or the like (16) to lock the edge (11) when it is inserted into the groove (12).
9. Panel according to any one of claims 1-8, characterized in that the ledge (10) is fixed in a recess on the under side (8) of the panel, whereby the under side of the ledge (10) and the rest of the under side of the panel are flush with each other.
10. Panel according to any one of claims 1-9, characterized in that at least one of the ledge (10) and the snapping web (13) is made of an elastic material such as plastics, rubber or the like.
- × 11. Panel according to any one of claims 1-10, characterized in that the panel is made of thermosetting laminate of so-called compact laminate type or of a water resistant or non water absorbing base with a surface layer consisting of paint, a thermoplastic foil, a paper sheet impregnated with thermosetting resin or of a thermosetting laminate.
- × 12. Panel according to claim 11, characterized in that the base under the surface layer consists of a board produced by pressing wood particles or wood chips with a thermoplastic.

WO 96/27719

PCT/SE96/00291

1/4

Fig. 1

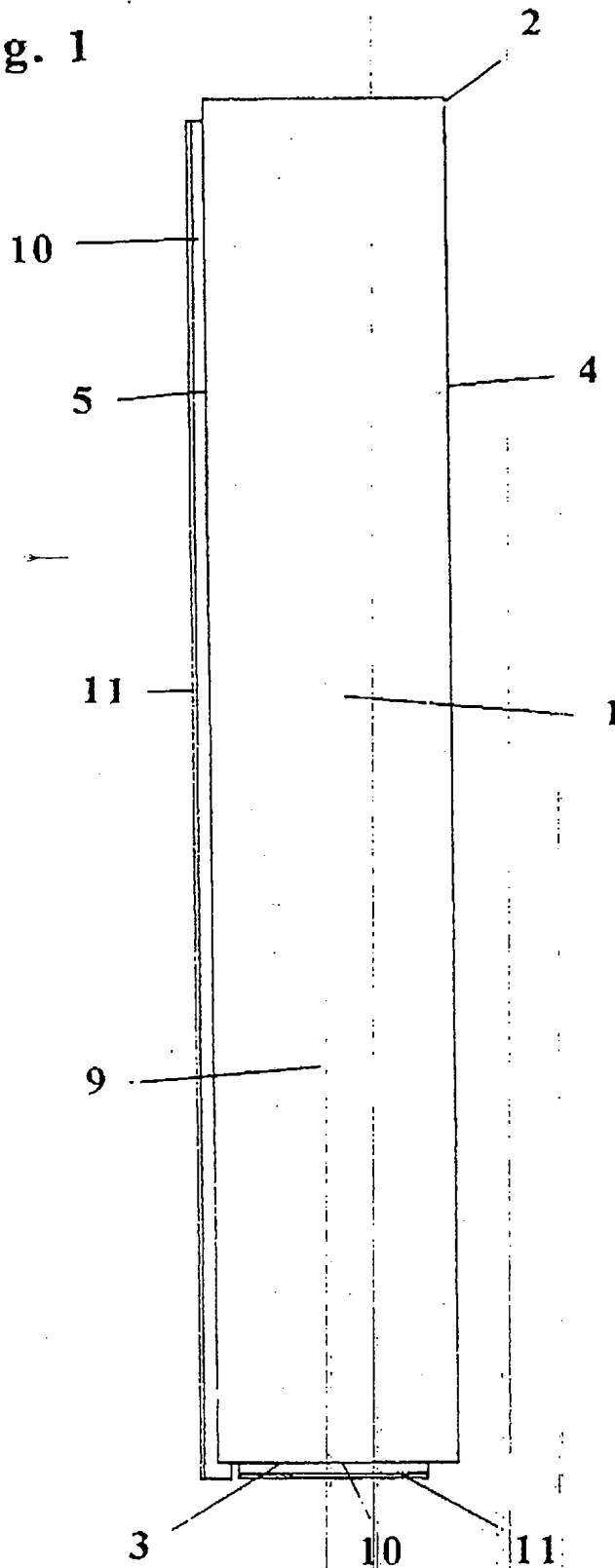

WO 96/27719

PCT/SE96/00291

Fig. 2

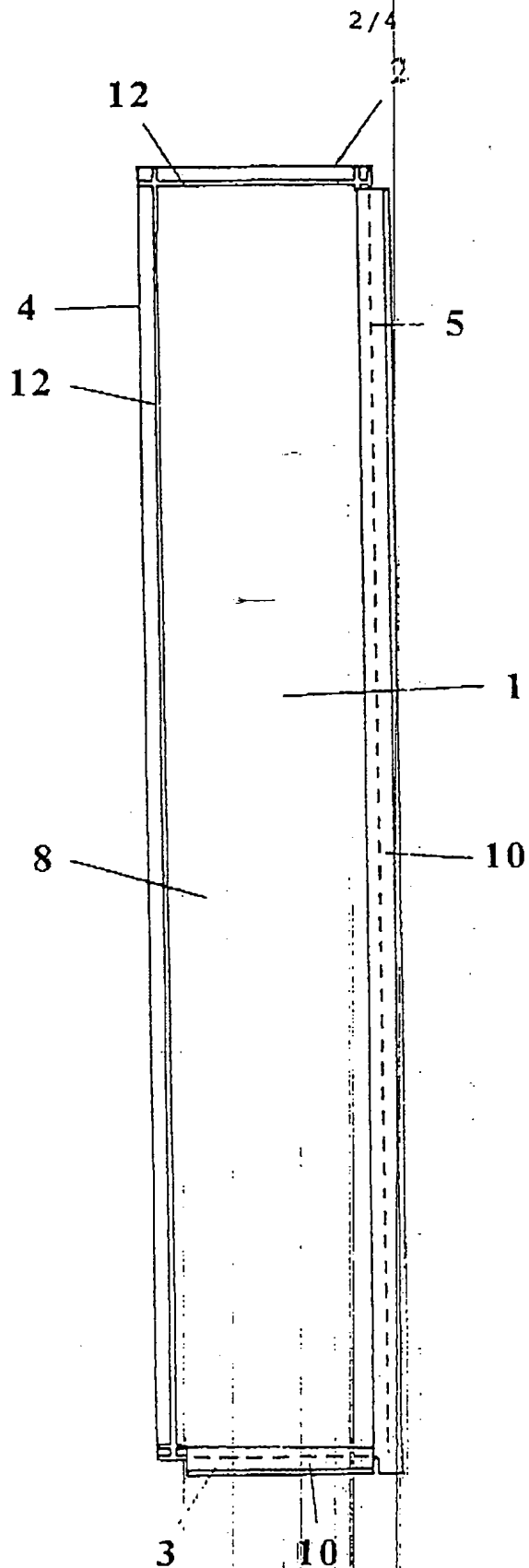

WO 96/27719

PCT/SE96/00291

3/4

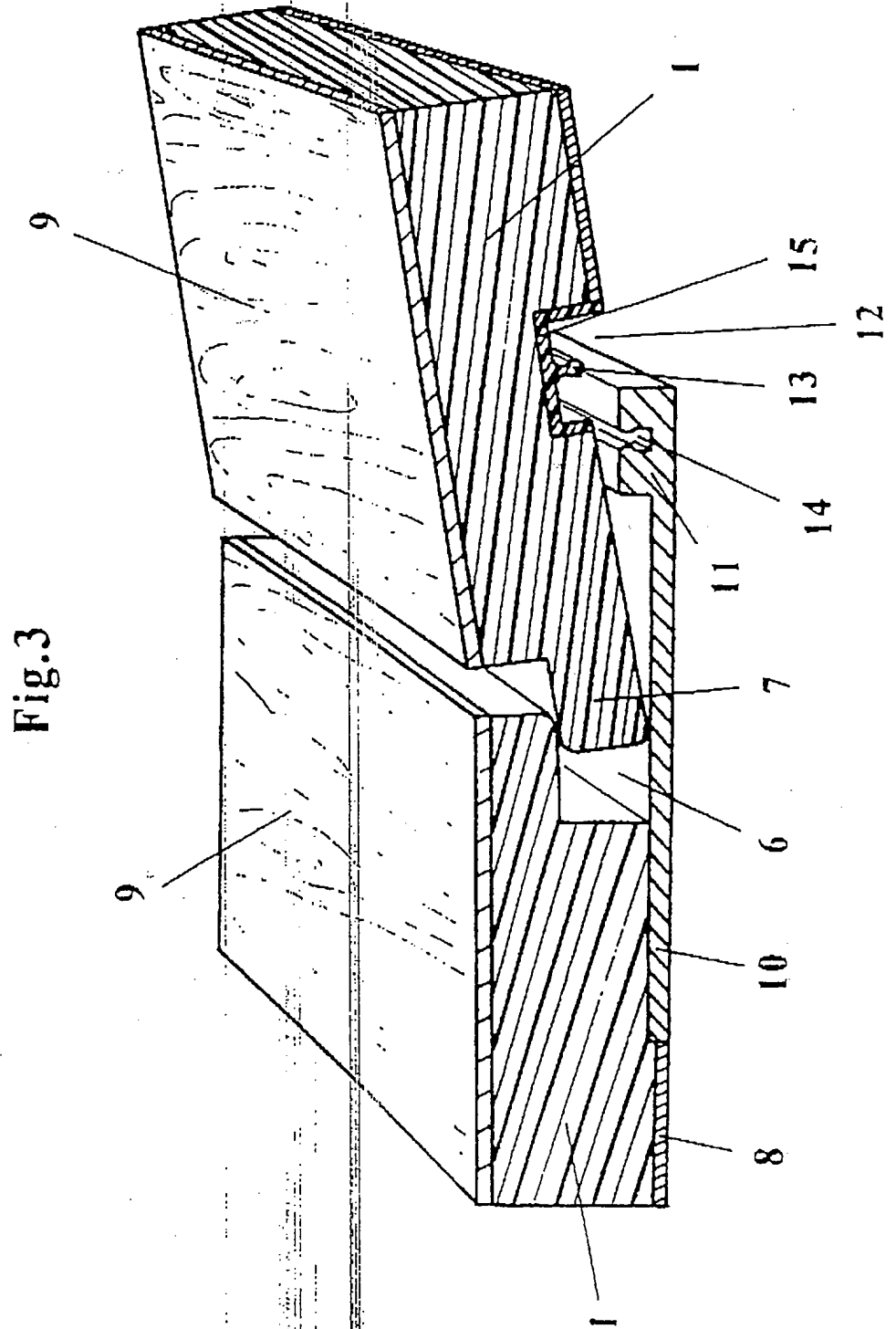

Fig. 3

WO 96/27719

PCT/SE96/00291

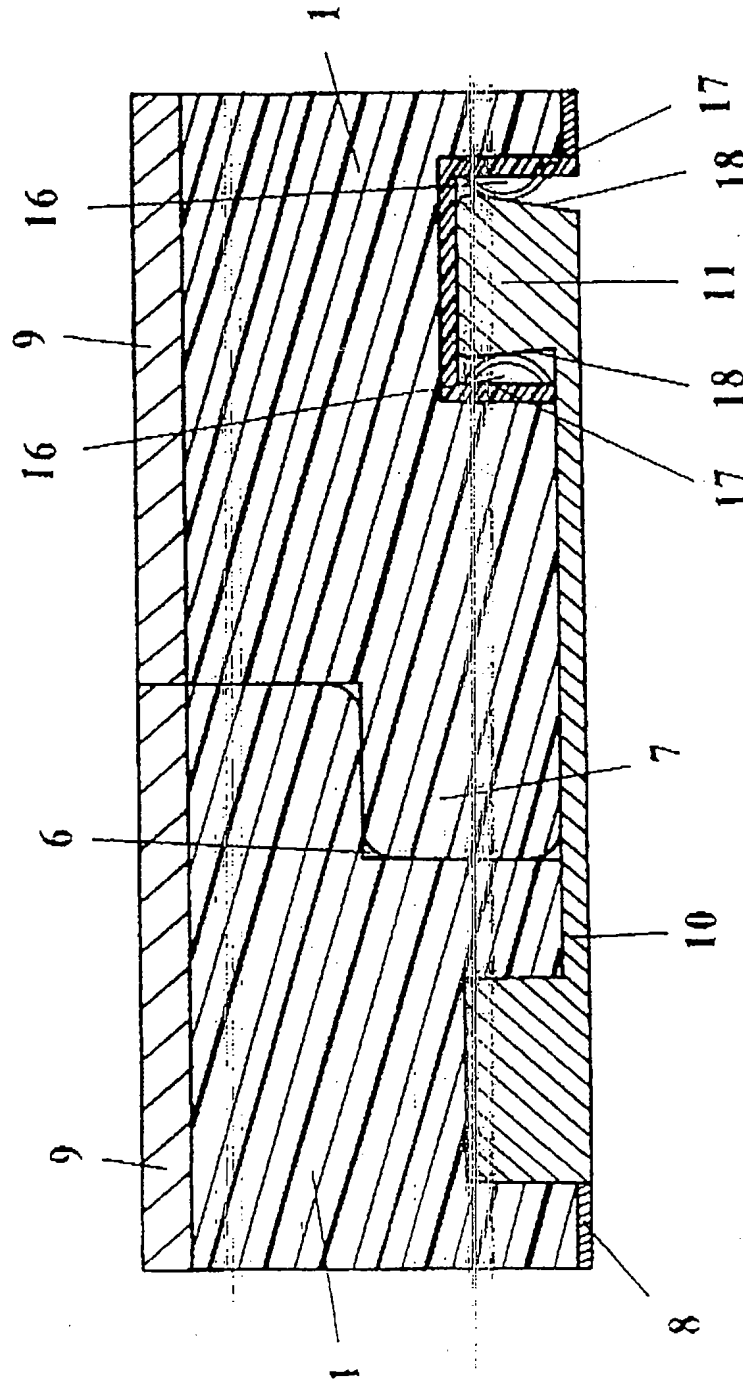

Fig. 4